



Instantor®

Technical Specification
Expansion Vessel
R-Type Heating



Product Code	R- Series: 710420 (8L), 710421 (12L), 710422 (18L), 710423(24L), RV- Series: 710424 (35L), 710425 (50L), 710445 (80L), 710450 (100L)
Description	Sanbra® Expansion Vessel. Fluid Group II.
Capacity & Connection:	8L (3/4"), 12L (3/4"), 19L (3/4"), 24L (1"), 35L (1"), 50L (3/4"), 80L (1"), 100L (1"),
Colour	RED [RAL 3000]
Max. Pressure (PS):	8 Bar
Max Operating Temp. (TS)	+100°C System
Min Operating Temp (TS)	-10°C (flowing fluid)
Material Specification	Main Body: Steel Connecting Flange: Galvanised Steel Membrane: EDPM Air Pre-charge: 1.5 Bar
Warranty:	All vessels come with a 24-month warranty period from date of purchase. See T&C.
Conformity to:	PED 2014/68/EU – CE/UKCA -Cat I - Module H EN13831, EN12100 ISO9001:2015 ISO14001:2015

Notice:

The Vessels weight must be adequately supported. Mounting from a wall plate is insufficient. The Pre-charge is 1.5 Bar but due to transportation & storage the installer should check the Pre charge and if required calibrate to 2 -4 % less than the systems M.O.P. Best practice is to install the vessel in a vertical position with the feed pipe gradually rising to the vessel's bottom threaded connection. Vessels should be serviced every year, with inspection of the Air pre charge, amending the pressure if required along with inspection and tightening of the flange and bolts with a label placed on the product identifying the service technician, the date of service & the pre-charge.

T: 01 842 6255 E: sales@Instantor.ie www.Instantor.ie

Sanbra Fyffe Ltd

Instantor Works, Santry Avenue, Santry, Dublin D09 K160

Doc Ref:TS710420

Issue V.2 February 2024 Page 1 of 2





Dimensions

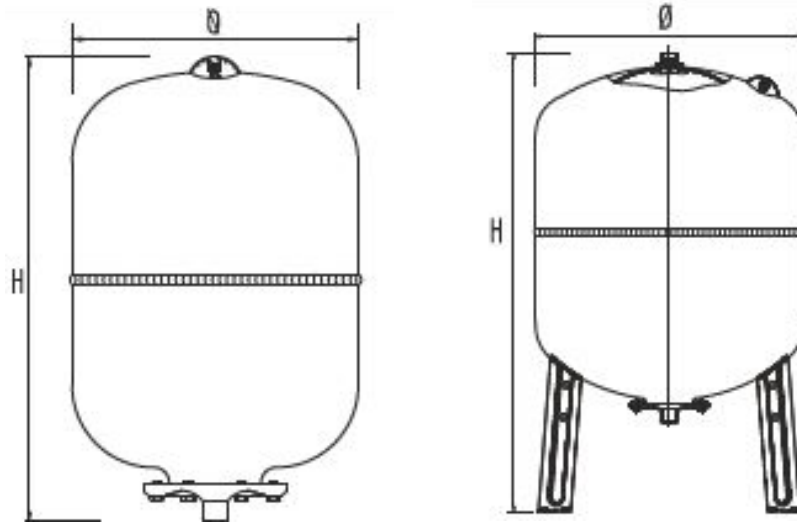

Code	Model	Height [H] mm	Diameter [Ø] mm	Connection	Packaging
710515	M2	240	120	½"	250 x 390 x 545
710420	R8	316	200	¾"	430 x 440 x 670
710421	R12	295	280	¾"	580 x 580 x 650
710422	R18	456	280	¾"	460 x 570 x 570
710423	R24	483	280	1"	510 x 570 x 570
710424	R35	440	365	1"	380 x 400 x 460
710425	R50	565	365	¾"	380 x 400 x 570
710445	RV80	856	415	1"	430 x 450 x 730
710450	RV100	675	495	1"	510 x 540 x 700

Note: A Fixture bracket must be used to secure the installation or other similar means of supporting the full weight of the vessel. Hanging via a Wallplate is insufficient support to the bodies weight.



T: 01 842 6255 E: sales@Instantor.ie www.Instantor.ie

Sanbra Fyffe Ltd

Instantor Works, Santry Avenue, Santry, Dublin D09 K160

Doc Ref:TS710420

Issue V.2 February 2024 Page 2 of 2

