

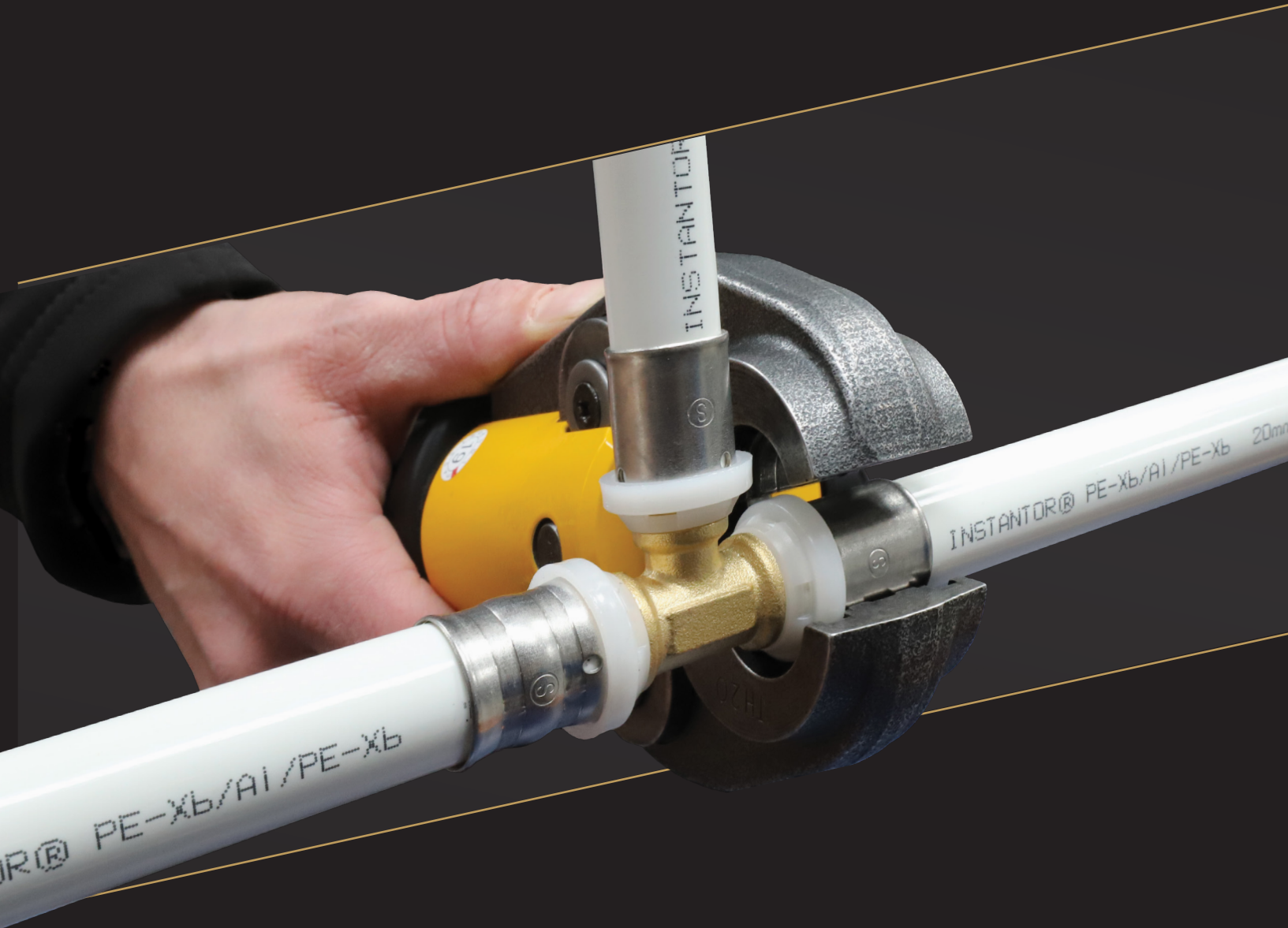

# Instantor®

## Press System



Superior Plumbing Products  
Manufactured by Sanbra Fyffe

[www.instantor.ie](http://www.instantor.ie)



Superior Plumbing Products  
Manufactured by **Sanbra Fyffe**



*Make the connection with us socially*



# Instantor<sup>®</sup>

## Press System



### Product Overview

NSAI Certified to EN ISO 21003 and WRAS approved. INSTANTOR<sup>®</sup> Press fittings are manufactured using the same high-grade CW617N brass as our market leading range of INSTANTOR<sup>®</sup> Brass Compression fittings.

Every fitting features two EPDM O rings on each connection which, when pressed correctly, delivers a water-tight seal in seconds. Quick to install in three simple steps – Cut, Calibrate & Press, saving on time and costs as less fittings are required when compared with traditional plumbing methods. INSTANTOR<sup>®</sup> Press fittings are designed for use in sanitary water supply and heating systems.

Watch the video at [www.instantor.ie](http://www.instantor.ie)

**Max Operating Pressure:** 10 bar  
**Max Operating Temperature:** 95°C  
**Max Peak Temperature (at 1 hour):** 110°C

Above specs relate to Instantor Press System combined with Instantor Pex-Al-Pex Multi Layer Pipe

### Features

- Brass body manufactured from CW617N brass to EN ISO 21003.
- Suitable for use with the following pipes:
  - Aluminium plastic composite / PE-X / PE-RT / PB/ Steel plastic composite
  - Manufactured as standard for use with Aluminium plastic composite pipe.
- Operating Temperatures 0°C to 110°C
- 304 Stainless Steel sleeves
- Three viewing inspection windows per stainless steel sleeve to allow a visual check so as to ensure the pipe is correctly inserted
- Application class: 2/6 bar, class 5/6 bar
- Sizes: 16mm, 20mm, 26mm & 32mm - WRAS Approved  
Sizes: 40mm & 50mm - WRAS Approval Pending
- TH profile
- EPDM O-rings

### Installation Instructions

1. Cut – Cut the pipe squarely to desired length using an appropriate cutting tool
2. Calibrate – Insert the reamer into the cut pipe and rotate, pushing slightly to remove all burrs and rough edges. NOTE, a poorly calibrated pipe could damage the O rings on insertion.
3. Connect and Press – Connect the pipe and fitting and check pipe is fully inserted in the inspection windows. The white of the pipe must be viewable through these holes. DO NOT USE SEALING AGENTS SUCH AS PTFE TAPE OR JOINTING COMPOUND. Use TH Profile Jaws to press.



# Fittings

## IP10 STRAIGHT COUPLER

CODE	SIZE	PACK QTY	PRICE
IP10001	16mm	10	
IP10002	20mm	10	
IP10003	26mm	10	
IP10004	32mm	10	
IP10005	40mm	10	
IP10006	50mm	5	
IP10007	63mm	1	



## IP10 STRAIGHT REDUCER

CODE	SIZE	PACK QTY	PRICE
IP10021	20 x 16mm	10	
IP10031	26 x 16mm	10	
IP10032	26 x 20mm	10	
IP10042	32 x 20mm	10	
IP10043	32 x 26mm	10	
IP10052	40 x 20mm	10	
IP10053	40 x 26mm	10	
IP10054	40 x 32mm	10	
IP10056	50 x 40mm	5	
IP10063	50 X 26mm	5	
IP10064	50 x 32mm	5	
IP10065	50 x 40mm	5	
IP10074	63 x 32mm	1	
IP10075	63 x 40mm	1	
IP10076	63 x 50mm	1	



## IP11 STRAIGHT COUPLER M.I. X PIPE

CODE	SIZE	PACK QTY	PRICE
IP11001	½" M x 16mm	10	
IP11012	½" M x 20mm	10	
IP11013	½" M x 26mm	10	
IP11021	¾" M x 16mm	10	
IP11002	¾" M x 20mm	10	
IP11023	¾" M x 26mm	10	
IP11032	1" M x 20mm	10	
IP11003	1" M x 26mm	10	
IP11034	1" M x 32mm	10	
IP11004	1¼" M x 32mm	10	
IP11045	1¼" M x 40mm	10	
IP11056	1½" M x 50mm	5	
IP11057	1½" M x 63mm	1	
IP11066	2" M x 50mm	1	
IP11067	2" M x 63mm	1	



**Note:** Fittings should be kept in original packaging to prevent O-ring lubrication drying out before use.

## IP12 STRAIGHT COUPLER F.I. X PIPE

CODE	SIZE	PACK QTY	PRICE
IP12001	½" F x 16mm	10	
IP12013	½" F x 26mm	10	
IP12021	¾" F x 16mm	10	
IP12002	¾" F x 20mm	10	
IP12023	¾" F x 26mm	10	
IP12032	1" F x 20mm	10	
IP12003	1" F x 26mm	10	
IP12034	1" F x 32mm	10	
IP12004	1¼" F x 32mm	10	
IP12045	1¼" F x 40mm	10	
IP12056	1½" F x 50mm	5	
IP12057	1½" F x 63mm	1	



## IP13 ADAPTOR

CODE	SIZE	PACK QTY	PRICE
IP13001*	½" C x 16mm	10	
IP13002	¾" C x 20mm	10	
IP13021	¾" C x 16mm	10	
IP13023	¾" C x 26mm	10	
IP13033	1" C X 26mm	10	
IP13034	1" C x 32mm	10	
IP13011*	15mm C x 16mm	10	
IP13012*	22mm C x 20mm	10	
IP13223*	22mm C x 26mm	10	
IP13035*	28mm C x 32mm	10	



## IP13 ELBOW ADAPTOR

CODE	SIZE	PACK QTY	PRICE
IP13101*	½" C x 16mm	10	
IP13102*	¾" C x 20mm	10	
IP13110*	15mm C x 16mm	10	
IP13111*	22mm C x 20mm	10	



Kiwa Reg4 Approved

\*Not WRAS Approved

**Note:** Fittings should be kept in original packaging to prevent O-ring lubrication drying out before use.

## IP14 SPIGOT

CODE	SIZE	PACK QTY	PRICE
IP14001*	16mm x 1/2"	10	
IP14011*	16mm x 15mm	10	
IP14002*	20mm x 3/4"	10	
IP14022*	20mm x 22mm	10	
IP14003*	26mm x 3/4"	10	
IP14033*	26mm x 22mm	10	
IP14004*	26mm x 1"	10	
IP14044*	26mm x 28mm	10	
IP14046*	32mm x 28mm	10	

Kiwa Reg4 Approved



## IP15 90° ELBOW

CODE	SIZE	PACK QTY	PRICE
IP15001	16mm	10	
IP15002	20mm	10	
IP15003	26mm	10	
IP15004	32mm	10	
IP15005	40mm	5	
IP15006	50mm	1	
IP15007	63mm	1	



## IP15 45° ELBOW

CODE	SIZE	PACK QTY	PRICE
IP15055	40mm	10	
IP15066	50mm	10	

## IP15 RADIATOR EXTENSION ELBOW

CODE	SIZE	PACK QTY	PRICE
IP15010	16mm x 300mm	10	
IP15011*	16mm x 100mm	10	

Kiwa Reg4 Approved



\*Not WRAS Approved

**Note:** Fittings should be kept in original packaging to prevent O-ring lubrication drying out before use.

## IP16 ELBOW M.I. X PIPE

CODE	SIZE	PACK QTY	PRICE
IP16001	½"M x 16mm	10	
IP16012	½"M x 20mm	10	
IP16002	¾"M x 20mm	10	
IP16023	¾"M x 26mm	10	
IP16032	1"M x 20mm	10	
IP16003	1"M x 26mm	10	
IP16034	1"M x 32mm	10	
IP16004	1¼"M x 32mm	10	



## IP17 ELBOW F.I. X PIPE

CODE	SIZE	PACK QTY	PRICE
IP17001	½"F x 16mm	10	
IP17012	½"F x 20mm	10	
IP17013	½"F x 26mm	10	
IP17002	¾"F x 20mm	10	
IP17023	¾"F x 26mm	10	
IP17032	1"F x 20mm	10	
IP17003	1"F x 26mm	10	
IP17034	1"F x 32mm	10	
IP17004	1¼"F x 32mm	10	
IP17001CP*	½"F x 16mm Chrome	10	



## IP18 EQUAL TEE

CODE	SIZE	PACK QTY	PRICE
IP18001	16mm	10	
IP18002	20mm	10	
IP18003	26mm	10	
IP18004	32mm	10	
IP18005	40mm	5	
IP18006	50mm	1	
IP18007	63mm	1	



\*Not WRAS Approved

**Note:** Fittings should be kept in original packaging to prevent O-ring lubrication drying out before use.

## IP18 REDUCING TEE

CODE	SIZE	PACK QTY	PRICE
IP18112	16 x 16 x 20mm	10	
IP18211	20 x 16 x 16mm	10	
IP18212	20 x 16 x 20mm	10	
IP18221	20 x 20 x 16mm	10	
IP18223	20 x 20 x 26mm	10	
IP18311	26 x 16 x 16mm	10	
IP18312	26 x 16 x 20mm	10	
IP18313	26 x 16 x 26mm	10	
IP18322	26 x 20 x 20mm	10	
IP18323	26 x 20 x 26mm	10	
IP18331	26 x 26 x 16mm	10	
IP18332	26 x 26 x 20mm	10	
IP18334	26 x 26 x 32mm	10	
IP18414	32 x 16 x 32mm	10	
IP18424	32 x 20 x 32mm	10	
IP18432	32 x 26 x 20mm	10	
IP18433	32 x 26 x 26mm	10	
IP18434	32 x 26 x 32mm	10	
IP18441	32 x 32 x 16mm	10	
IP18442	32 x 32 x 20mm	10	
IP18443	32 x 32 x 26mm	10	
IP18552	40 x 40 x 20mm	5	
IP18553	40 x 40 x 26mm	5	
IP18554	40 x 40 x 32mm	5	
IP18663	50 x 50 x 26mm	1	
IP18664	50 x 50 x 32mm	1	
IP18665	50 x 50 x 40mm	1	
IP18774	63 x 63 x 32mm	1	
IP18775	63 x 63 x 40mm	1	
IP18776	63 x 63 x 50mm	1	



## IP19 WALLPLATE ELBOW

CODE	SIZE	PACK QTY	PRICE
IP19001	½" F x 16mm	10	
IP19012	½" F x 20mm	10	



## IP30 TEE

CODE	SIZE	PACK QTY	PRICE
IP30001	16 x 16 x ½" F	10	
IP30002	20 x 20 x ¾" F	10	
IP30331*	26 x 26 x ½"	10	
IP30003	26 x 26 x 1" F	10	
IP30443	32 x 32 x 1" F	10	



\*Not WRAS Approved

**Note:** Fittings should be kept in original packaging to prevent O-ring lubrication drying out before use.



## IP51 STOP END

CODE	SIZE	PACK QTY	PRICE
IP51001	16mm	10	
IP51002	20mm	10	
IP51003	26mm	10	
IP51004	32mm	10	



## IP20 NUT AND INSERT ADAPTOR TO COPPER COMPRESSION

CODE	SIZE	PACK QTY	PRICE
IP20001*	1/2" x 16mm	10	
IP20002*	15mm x 16mm	10	
IP20003*	3/4" x 20mm	10	
IP20004*	1" x 26mm	10	
IP20005*	22mm x 20mm	10	
IP20006*	28mm x 26mm	10	
IP20001CP*	1/2" x 16mm	10	
IP20002CP*	15mm x 16mm	10	



\*IP20002CP is suitable for use with all 15mm Sanbra Fyffe Standard TRV's and Rad Valves.

Kiwa Reg4 Approved

## IP20 PRESS ADAPTOR TO COPPER COMPRESSION

CODE	SIZE	PACK QTY	PRICE
IP20060	1/2" x 16mm	10	
IP20061	15mm x 16mm	10	
IP20062	3/4" X 20mm	10	



## IP21 PRESS ADAPTOR TO COPPER PRESS

CODE	SIZE	PACK QTY	PRICE
IP21001*	16mm x 15mm	10	
IP21002*	20mm x 22mm	10	
IP21003*	26mm x 28mm	10	
IP21004*	16mm x 1/2"	10	
IP21005*	20mm x 3/4"	10	
IP21006*	26mm x 1"	10	



Kiwa Reg4 Approved

## IP70 ISOLATING VALVE

CODE	SIZE	PRICE
IP700051*	16mm x 1/2"	
IP700049*	16mm x 15mm	

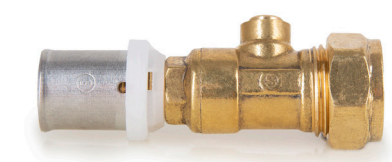

\*Not WRAS Approved

**Note:** Fittings should be kept in original packaging to prevent O-ring lubrication drying out before use.

## IP80 LEVER BALL VALVE

CODE	SIZE	PACK QTY	PRICE
IP80001	16mm	10	
IP80002	20mm	5	
IP80003	26mm	5	
IP80004	32mm	5	



Please specify red or blue handles when ordering (use 'R' or 'B' after code above)  
 Not WRAS Approved - WRAS Approved Lever Ball Valves Available - Please contact our Sales Office.

## FLEXIBLE HOSES

CODE	SIZE	PRICE
IP700110*	½" x 16mm IP x 300mm	
IP700109*	½" x 16mm IP x 500mm	

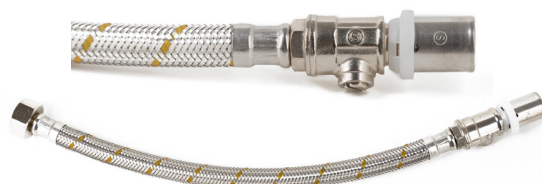

## THERMOSTATIC RADIATOR VALVES

CODE	SIZE	PRICE
IP771095*	16mm TRV ONLY	
IP771096*	16mm TRV PACK	



## BRASS MANIFOLDS

CODE	SIZE	PRICE
771871C*	¾" x ½" x 2 Port + IP Adaptor	
771872C*	1" x ½" x 2 Port + IP Adaptor	
771874C*	¾" x ½" x 3 Port + IP Adaptor	
771875C*	1" x ½" x 3 Port + IP Adaptor	
771877C*	¾" x ½" x 4 Port + IP Adaptor	
771878C*	1" x ½" x 4 Port + IP Adaptor	

## IP BRASS MANIFOLDS

CODE	SIZE	PRICE
IP771871*	¾" x 16mm 2 Port Manifold	
IP771874*	¾" x 16mm 3 Port Manifold	
IP771877*	¾" x 16mm 4 Port Manifold	
IP771872*	1" x 16mm 2 Port Manifold	
IP771875*	1" x 16mm 3 Port Manifold	
IP771878*	1" x 16mm 4 Port Manifold	



CODE	SIZE	PRICE
771897PW	1" x ¾" x 4 Port Manifold	
771896PW	1" x ¾" x 3 Port Manifold	
771879PW	1" x ¾" x 2 Port Manifold	

\*Not WRAS Approved

**Note:** Fittings should be kept in original packaging to prevent O-ring lubrication drying out before use.

## IP BRASS MANIFOLDS (WITH ISO VALVES)

CODE	SIZE	PRICE
IP771892*	¾" x 16mm 2 Port Manifold with ISO Valve	
IP771894*	¾" x 16mm 3 Port Manifold with ISO Valve	
IP771895*	¾" x 16mm 4 Port Manifold with ISO Valve	
IP771893*	1" x 16mm 2 Port Manifold with ISO Valve	

MANIFOLD BRACKETS AVAILABLE - SEE PAGE 11



## IP MANIFOLD BLANK CAP

CODE	SIZE	PACK QTY	PRICE
IP51011*	½"	-	

## IP27 TAP CONNECTOR

CODE	SIZE	PACK QTY	PRICE
IP27001*	16mm x 15mm	10	



## SHOWER BRACKET

CODE	SIZE	PRICE
IP93001	16mm	



## IP STAINLESS STEEL SLEEVES

CODE	SIZE	PRICE
IP90001	16mm	
IP90002	20mm	
IP90003	26mm	
IP90004	32mm	



## IP SPARE BRASS SPLIT RING

CODE	SIZE	PACK QTY	PRICE
IP90005	16mm	10	
IP90006	20mm	5	
IP90007	26mm	5	
IP90008	32mm	5	



\*Not WRAS Approved

**Note:** Fittings should be kept in original packaging to prevent O-ring lubrication drying out before use.

# Tools and Accessories

## DRILL PIPE REAMERS

CODE	SIZE	PRICE
IP20050	Full Kit incl. 16, 20, 26 & 32 mm + Manual T-Handle	
IP20051	16mm Drill Reamer	
IP20052	20mm Drill Reamer	
IP20053	26mm Drill Reamer	
IP20054	32mm Drill Reamer	
IP20059	Manual T-Handle	



## MANUAL PIPE REAMER

CODE	SIZE	BOX QTY	PRICE
IP20010	16mm – 26mm	40	
IP20011	20mm – 32mm	30	



## PIPE CUTTER

CODE	SIZE	BOX QTY	PRICE
IP20016	Up to 32mm	-	
IP20009	Up to 63mm	-	



## IP20 BENDING SPRING PACK (INTERNAL & EXTERNAL)

CODE	SIZE	PACK QTY	PRICE
IP20030	16mm	10	
IP20031	20mm	10	
IP20032	26mm	10	
IP20033	32mm	5	



## PIPE DECOILER

CODE	SIZE	BOX QTY	PRICE
IP20017	Suits All Sizes	-	



## PUSH FIT PRESSURE TEST FITTING

CODE	SIZE	BOX QTY	PRICE
IP20071*	16mm Incl Tool	L	
IP20072*	20mm Incl. Tool	L	
IP20075*	16mm Removal Tool	L	
IP20076*	20mm Removal Tool	L	

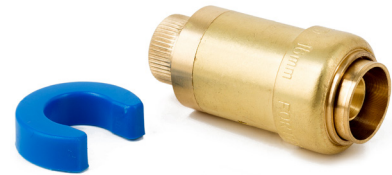

## PRESSURE TEST GAUGE

CODE	SIZE	PRICE
IP20077*	Gauge For Pressure Test Fittings	



## ADHESIVE TRACKING STRIP

CODE	SIZE	PACK QTY	PRICE
IP20019	16mm x 1M	-	



## PIPE STAPLE

CODE	SIZE	PACK QTY	PRICE
IP20014	16mm x 40mm	30	
IP20012	16mm x 60mm	30	

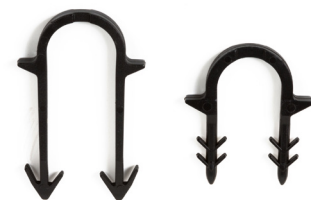

## MANIFOLD BRACKET

CODE	SIZE	PACK QTY	PRICE
771910	¾"	20	
771911	1"	18	

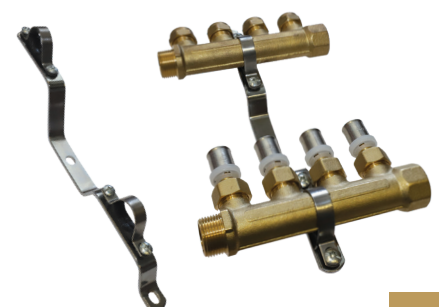

\*Not WRAS Approved

# Tools and Accessories

## INSTANTOR 18V MINI PRESS TOOL

CODE	DESCRIPTION	PRICE
IT2020	Instantor <b>Mini</b> Press Tool 18V	
IT2020THK	Instantor <b>Mini</b> Press Tool 18V Kit includes 16, 20, 26 & 32mm <b>TH Jaws</b> , 2 x 4.0Ah batteries & case Output - 19kN	
IT2020MK	Instantor <b>Mini</b> Press Tool 18V Kit includes 15, 22 & 28mm <b>M Jaws</b> , 2 x 4.0Ah batteries & case Output - 19kN	
IT2020VIK	Instantor <b>Mini</b> Press Tool 18V Kit includes ½", ¾" & 1" <b>VI Jaws</b> , 2 x 4.0Ah batteries & case Output - 19kN	



## INSTANTOR 18V LARGE PRESS TOOL

CODE	DESCRIPTION	PRICE
IT2040	Instantor <b>Large</b> Press Tool 18V	
IT2040THK	Instantor <b>Large</b> Press Tool 18V Kit includes 40, 50 & 63mm <b>TH Jaws</b> & Adaptor Tongs (Required for 50 & 63mm Jaws), 2 x 4.0Ah batteries & case Output - 32kN	



## ADDITIONAL ITEMS

CODE	DESCRIPTION	PRICE
IT20042	Instantor 4.0Ah Battery	
IT20029	Instantor Adaptor TH50 / TH63 / M42 / M54	



## INSTANTOR PRESS JAWS

CODE	DESCRIPTION	PRICE
IT20019	Instantor ½" VI Jaws	
IT20020	Instantor ¾" VI Jaws	
IT20021	Instantor 1" VI Jaws	
IT20022	Instantor 16mm TH Jaws	
IT20023	Instantor 20mm TH Jaws	
IT20024	Instantor 26mm TH Jaws	
IT20025	Instantor 32mm TH Jaws	
IT20026	Instantor 40mm TH Jaws	
IT20027	Instantor 50mm TH Jaw Ring	
IT20028	Instantor 63mm TH Jaw Ring	
IT20030	Instantor 15mm M Jaws	
IT20031	Instantor 22mm M Jaws	
IT20032	Instantor 28mm M Jaws	
IT20033	Instantor 35mm M Jaws	
IT20034*	Instantor 42mm M Jaw Ring	
IT20035*	Instantor 54mm M Jaw Ring	

\*Requires Adaptor Tong IT20029



## INSTANTOR PRESS JAW CASE & SETS

CODE	DESCRIPTION	PRICE
IT20050	Instantor Press Jaw Case	
IT20050THK	Instantor <b>TH</b> Press Jaw Case	
IT20050VIK	Instantor <b>VI</b> Press Jaw Case	
IT20050MK	Instantor <b>M</b> Press Jaw Case	

## REMS MANUAL PRESS TOOL

CODE	SIZE	PRICE
IP20026	REMS Manual Press Tool	



## REMS HAND PRESSURE TESTING PUMP

CODE	SIZE	PRICE
IP20043	60 bar Pressure Test Pump	



## REMS MANUAL DEBURRING TOOL

CODE	SIZE	PRICE
IP20015	Ø3-35mm	



## IP PIPE STRAIGHTENER

CODE	SIZE	PRICE
IP20013	IP Pipe Straightener	

**Note:** Fittings should be kept in original packaging to prevent O-ring lubrication drying out before use.



## IP DRILL REAMER

CODE	SIZE	PRICE
IP20066	40mm	
IP20067	50mm	

## DRILL REAMER CASE

CODE	SIZE	PRICE
IP20049	Drill Reamer Case	

**Note:** Fittings should be kept in original packaging to prevent O-ring lubrication drying out before use.



# Instantor®

## Pex-Al-Pex Pipe

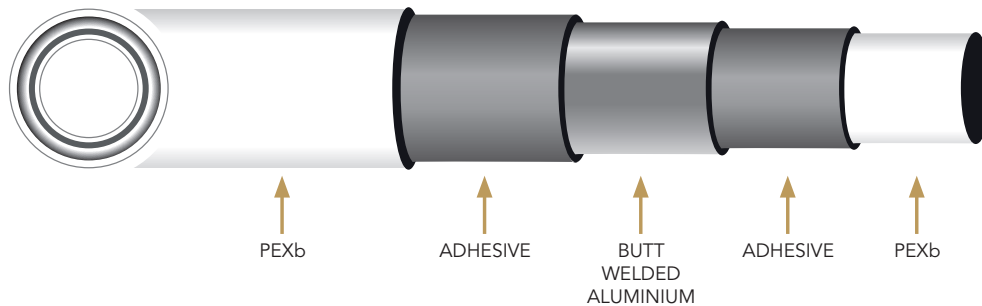

### Product Overview

**INSTANTOR® Pex-Al-Pex** (PE-xB/Al/PE-xB) is a multilayer pipe NSAI Certified to EN ISO 21003 and WRAS approved, combining all the advantages of metal and plastic pipe.

This pipe is constructed with a double inner and outer layer of Silane method crosslinked polyethylene PE-xB, then bound by quality adhesive to a longitudinally TIG butt welded

100% oxygen tight aluminium layer. It is this aluminium layer that allows the pipe to maintain its shape after bending. Total hygiene and high corrosion resistance is ensured as fluids come in contact with the inner PE-xB layer only.

**MULTI APPLICATIONS: Potable water, underfloor heating and all general plumbing and heating applications.**



### FEATURES

- This is a more cost effective pipe system when compared with conventional piping systems
- All the combined advantages of metal and plastic pipes
- Lightweight, flexible and maintains its shape after bending
- Cost effective - requires less fittings than traditional methods
- Available in
  - **Coils** - 16mm x 100M/200M/500M, 20mm x 100M, 26mm x 50M, 32mm x 50M
  - **Insulated Coils** - 16mm x 50M/100M, 20mm x 50M, 26mm x 25M/50M, 32mm x 25M
  - **Lengths** - 16, 20, 26, 32, 40, 50 & 63mm x 4M
- Butt welded aluminium pipe is 100% oxygen & water vapour tight
- Excellent heat preservation
- Highly corrosion resistant
- Low factor of linear expansion
- Low noise emission due to plastic properties of pipe
- Highly temperature and pressure resistant
- Guarantee - 10 years on system, 50 years on materials

### INSTANTOR® PEXB/AL/PEXB PIPE LENGTHS

CODE	SIZE	BUNDLE QTY	PRICE PER LENGTH
IPAP111	16 x 4M	50	
IPAP112	20 x 4M	35	
IPAP113	26 x 4M	20	
IPAP114	32 x 4M	12	
IPAP115	40 x 4M	6	
IPAP116	50 x 4M	5	
IPAP117	63 x 4M	5	

### INSTANTOR® PEXB/AL/PEXB PIPE COILS



CODE	SIZE	PALLET QTY	PRICE PER COIL
IPAP101	16 x 100M	10	
IPAP102	20 x 100M	10	
IPAP103	26 x 50M	10	
IPAP104	32 x 50M	10	
IPAP105	16 x 500M	5	
IPAP106	16 x 120M	5	
IPAP107	16 x 200M	5	

# INSTANTOR® PEXB/AL/PEXB PIPE TECHNICAL SPECIFICATIONS

UNIT OF MEASUREMENT		IPAP101 IPAP111	IPAP102 IPAP112	IPAP103 IPAP113	IPAP104 IPAP114	IPAP105 -	IPAP107 -	- IPAP115	- IPAP116
Outer Diameter	mm	16	20	26	32	16	16	40	50
Inner Diameter	mm	12	16	20	26	12	12	32	41
Weight	kg/M	0.110	0.147	0.268	0.355	0.110	0.110	0.557	0.797
Thickness of Aluminium	mm	0.25	0.3	0.35	0.5	0.25	0.25	0.5	0.5
Total Thickness	mm	2	2	3	3	2	2	4	4.5
Coils Length	M	100	100	50	50	500	200	-	-
Straight Lengths	M	4	4	4	4	-	-	4	4
Volume of water	l/m	0.113	0.201	0.314	0.531	0.113	0.113	0.803	1.319
Internal roughness	µm	7							
Thermal conductivity at Delta T 40°C	W/mk	0.43							
Coefficient of expansion	mm/m°C	0.025							
Degree of crosslinking	°C	≥65°C							
Oxygen permeability	mg/l	0							
Colour		White							
Type		PE-xB/Al/PE-xB multilayer pipe							
Field of application		Plumbing in civil, industrial and commercial applications							
Fluid		Potable water, technical water, and water glycol(*)							
Max peak temperature	°C	110							
Minimum operating temperature(*)	°C	0							
Maximum operating pressure at 95°C	bar	6							
Maximum operating pressure at 20°C	bar	10							
Duration at 95°C and 6 bar		Time duration to be determined by service conditions							
Storage		Avoid prolonged exposure to direct sunlight							
Minimum bend radius		5 times the diameter							

(\*) In the case of water glycol, in order to define the minimum operating temperature, it is necessary to know the elements of the mixture and the various concentrations.

## APPLICATION CLASS TABLE (ISO 21003-1)

Application Class	Design Temperature T <sub>D</sub> °C	Time <sup>b</sup> at T <sub>D</sub> Years	T <sub>max</sub> °C	Time at T <sub>max</sub> years	T <sub>mal</sub> °C	Time at T <sub>mal</sub> h	Typical field of application
1 <sup>a</sup>	60	49	80	1	95	100	Hot water supply (60°C)
2 <sup>a</sup>	70	49	80	1	95	100	Hot water supply (70°C)
4 <sup>b</sup>	20 + Cumulative 40 + Cumulative 60	2.5 20 25	70	2.5	100	100	Underfloor heating and low-temperature radiators
5 <sup>b</sup>	20 + Cumulative 60 + Cumulative 80	14 25 10	90	1	100	100	High-temperature radiators

<sup>a</sup> A country may select either class 1 or class 2 in conformity with its nation regulations.

<sup>b</sup> Where more than one design temperature for time and associated temperature appears for any class, they should be aggregated. "Plus cumulative" in the table implies a temperature profile of the mentioned temperature over time (e.g. the design temperature profile for 50 years for class 5 is 20°C for 14 years followed by 60°C for 25 years, 80°C for 10 years, 90°C for 1 year and 100°C for 100h).

NOTE: For values of T<sub>D</sub>, T<sub>max</sub> and T<sub>mal</sub> in excess of those in the table, this International Standard does not apply. In the case of water glycol, in order to define the minimum operating temperature, it is necessary to know the elements of the mixture and the various concentrations.



# Instantor®

## Pex-Al-Pex Pipe

### Product Overview

**INSTANTOR® PEX-AL-PEX (PE-xB/Al/PE-xB) INSULATED** multilayer pipe is an insulated multilayer pipe for multi-applications.

Enclosed in a scratch resistant, closed cell polyethylene foam insulating sheath, this pipe is constructed with a double inner and outer layer of Silane method crosslinked polyethylene PE-xB, then bound by quality adhesive to a butt welded 100% oxygen tight aluminium layer. It is this aluminium layer that allows the pipe to maintain its shape after bending.

Total hygiene and high corrosion resistance is ensured as fluids come in contact with the inner PE-xB layer only.

**MULTI APPLICATIONS:**  
Potable water and all general plumbing and heating applications.

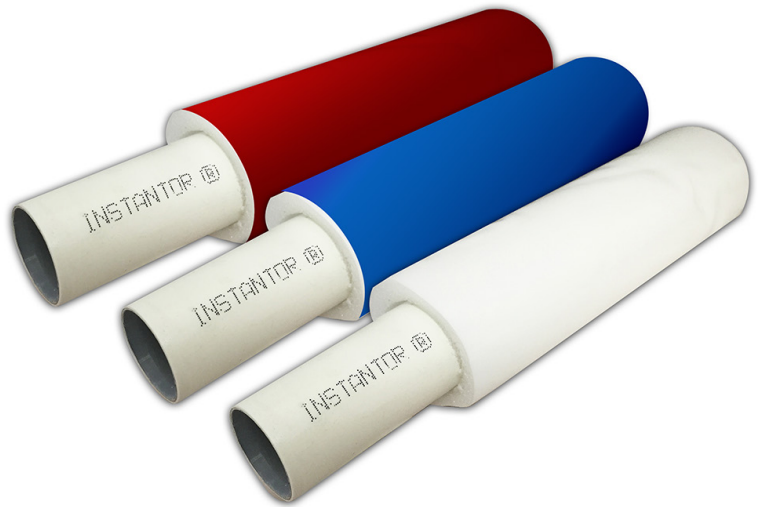

WHITE		RED		BLUE			
Code	Price €	Code	Price €	Code	Price €	Size	Pallet Qty
IPAP201		IPAP301		IPAP401		16 X 100M	10
IPAP202		IPAP302		IPAP402		20 X 50M	10
IPAP203		IPAP303		IPAP403		26 X 25M	10
IPAP204		IPAP304		IPAP404		32 x 25M	10
IPAP205		-		-		26 x 50M	-

### PEX-AL-PEX - INCREASED INSULATION

CODE	PART L COMPLIANT	SIZE	INSULATION THICKNESS	LINEAR HEAT LOSS	MAX PERMISSIBLE HEAT LOSS	PRICE
IPAP501	YES	16mm x 50M	9mm	7.008 W/m	7.89 W/m	
IPAP502	YES	20mm x 50M	13mm	7.436 W/m	9.12 W/m	
IPAP503	YES	26mm x 25M	12mm	9.491 W/m	10.07 W/m	

Calculated as per ISO 12241. Water temperature 60°, with still air temperature 15°

# INSTANTOR® PEXB/AL/PEXB INSULATED PIPE COILS TECHNICAL SPECIFICATIONS

	UNIT OF MEASUREMENT	IPAP201 IPAP301 IPAP401	IPAP202 IPAP302 IPAP402	IPAP203 IPAP303 IPAP403	IPAP204 IPAP304 IPAP404	IPAP205	IPAP501	IPAP502	IPAP503
Outer diameter	mm	16	20	26	32	26	16	20	26
Sheath thickness for heating	mm	6	6	6	6	6	9	13	12
Diameter pipe + sheath (heating)	mm	28	32	38	44	38	34	46	50
Aluminium thickness	mm	0.25	0.3	0.35	0.5	0.35	0.25	0.30	0.35
Roll length	M	100	50	25	25	50	50	50	25
Volume of water	l/m	0.113	0.201	0.314	0.531	0.314	0.113	0.201	0.314
Internal roughness	µm	7							
Thermal conductivity at 20°C	W/mk	0.04							
Coefficient of expansion	kg/m <sup>3</sup>	35 to 45							
Degree of crosslinking	%	≥65%							
Oxygen permeability	mg/l	0							
Colour		White / Red / Blue							
Pipe material		PE-xB/Al/PE-xB multilayer pipe							
Sheath material		closed-cell polyethylene foam PE-LD							
Scratch-resistant finish layer		closed-cell polyethylene foam PE-LD							
Field of application		Plumbing in civil, industrial and commercial applications							
Fluid		Potable water, technical water, and water glycol(*)							
Max peak temperature	°C	110							
Minimum operating temperature(*)	°C	0							
Maximum operating pressure at 95°C	bar	6							
Maximum operating pressure at 20°C	bar	10							
Duration at 95°C and 6 bar		Time duration to be determined by service conditions							
Storage		Avoid prolonged exposure to direct sunlight							
Minimum bend radius(**)		5 times the diameter							
Insulation Thickness (round)	mm	6	6	6	6	6	9	13	12
Fire Classification		<b>B2</b> (DIN 4102) / <b>E</b> (EN 13501-1:2007 A1:2009)							

(\*)Reference is made to a sheathed pipe and the use of a suitable water glycol mix.

(\*\*)Take the thickness of the sheath into account when bending a pipe with a bender.

e.g.: Ø16 sheath: total thickness=28mm,use bender with Ø26 profile.

See page 15 for Application Class Table (ISO 21003-1)





**Instantor<sup>®</sup>**  
Press System

# Superior Plumbing Products Manufactured by Sanbra Fyffe



# Instantor<sup>®</sup>

## Press System

## Certification

**NSAI**  
Certificate of Registration  
of Quality Management System  
to I.S. EN ISO 9001:2015

**Sanbra Fyffe Ltd (Instantor)**  
Instantor Works  
Santry Avenue  
Santry  
Dublin 9  
Ireland

NSAI certifies that the abovementioned company has been assessed and deemed to comply with the provisions of the standard referred to above in respect of:-  
The supply of brassware compression fittings and the distribution of plumbing and heating equipment.

Registration Number: 18-0197  
Date of Registration: 19 February 2012  
Last Assessment on: 18 August 2020  
Valid from: 1 October 2020  
Next review on: 1 October 2023

**WRAS**  
APPROVED PRODUCT

This certifies that  
**SANBRA FYFFE LTD.**  
has had the undermentioned product examined, tested and found, when correctly installed, to comply with the requirements of the United Kingdom Water Supply (Water Fittings) Regulations and Scottish Water Byelaws.

**"INSTANTOR PRESS" RANGE OF PRESS FIT FITTINGS FOR USE WITH INSTANTOR MULTI-LAYERED PIPE (FOR MODELS AND SIZES COVERED BY THE SCOPE OF THE APPROVAL PLEASE CONSULT THE ACCOMPANYING WRAS APPROVAL LETTER)**

The certificate by itself is not evidence of a valid WRAS Approval. Confirmation of the current status of an approval must be obtained from the WRAS Directory ([www.wras.co.uk/directory](http://www.wras.co.uk/directory))

The product so mentioned will be valid until the end of:  
**April 2023**

1804354  
Certificate No.

J Funnell  
Secretary

Chairman, Product Assessment Group

**kiwa**

Certificate number: 2207718 (1)

Issued: 21/07/2023  
Expires: 21/07/2025

**Kiwa Regulation 4 (KUKreg4) Certification**  
Evaluation Guideline – Kiwa UK – EG004 – Regulation 4(1)(a)  
Model number(s) – see Appendix

**Sanbra Fyffe Ltd.**

Kiwa Watertec declares that legitimate confidence exists in the products specified in this certificate and supplied by the above organisation be relied upon to comply with the Kiwa Evaluation Guideline referred to above.

Which verifies the requirements of:  
Regulation 4(1)(a) of the Water Supply (Water Fittings) Regulations 1999 England & Wales; 2009 Northern Ireland and 2016 Byelaws Scotland.

This certificate has been issued in accordance with the Kiwa regulations for product certification.  
Signed on behalf of Kiwa Watertec:

David Jay, Business Unit Manager – Authorized Signatory  
Kiwa Watertec

Publication of this certificate is advised.  
Products are intended to be used in the UK only. For other countries, other (National) requirements will apply. See [www.kiwa.com/technical-support/technical-support](http://www.kiwa.com/technical-support/technical-support) to ensure that the certificate is still valid.

**CERTIFICATE**

kiwa  
KUKreg4

Page 1 of 3

T +353 1842 6255 E [sales@instantor.ie](mailto:sales@instantor.ie) [www.instantor.ie](http://www.instantor.ie)

**Sanbra Fyffe Ltd.**

Instantor Works, Santry Avenue, Santry, Dublin D09 K160



Make the connection with us socially

22.11 - Unpriced